

# 12295 Notenpultleuchte

## 1. Ausstattung & Abmessungen

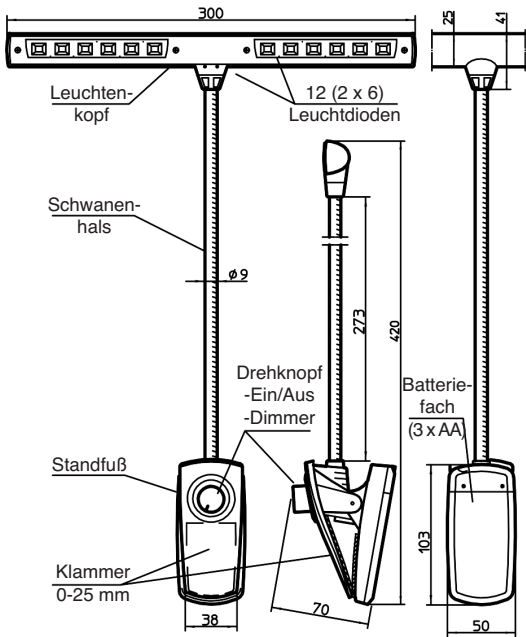

## 2. Batterien/Akkus einsetzen oder wechseln

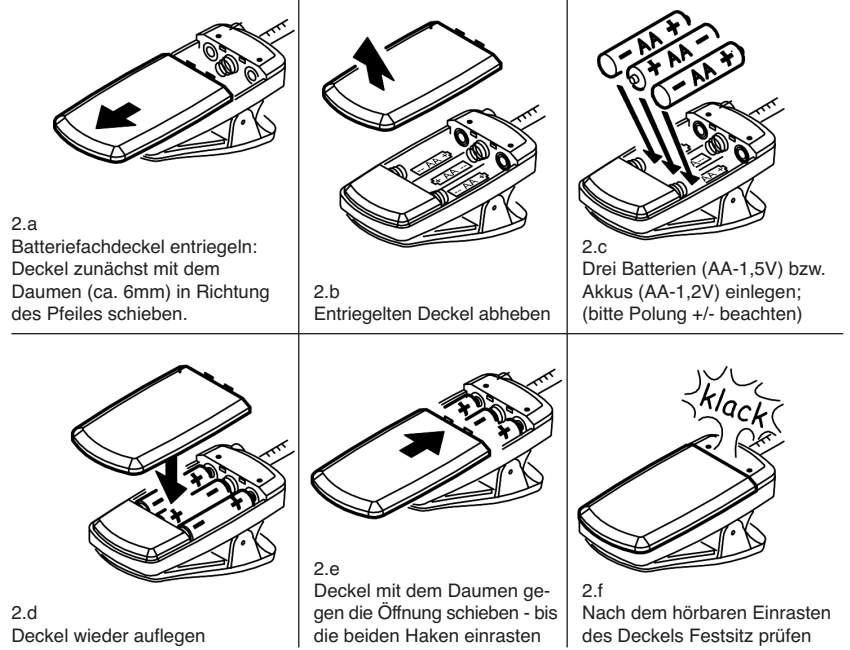

## 3. Lampe platzieren

### 3.a an PLATTEN

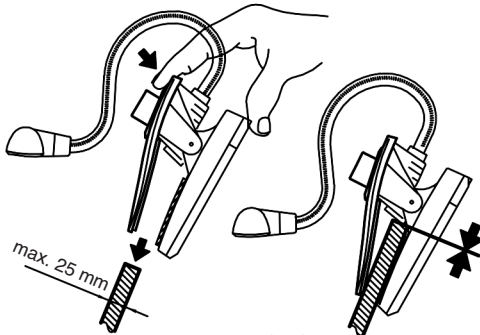

- 3.a.1 Klammer drücken und über die Notenpult- oder sonstige Platte (max.25mm) schieben...
- 3.a.2 ...bis die Platte am unteren Anschlag der Klammer innen anstößt

### 3.b an K&M-NOTENKÖPFEN

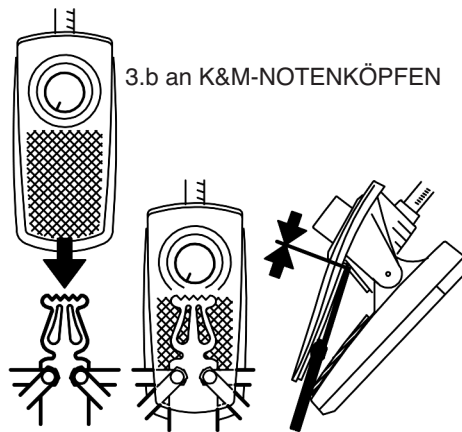

- 3.b.1 Klammer drücken und über die mittige platzierte Lyra des Notenkopfes schieben...
- 3.b.2 ...bis die Platte am oberen Anschlag innen anstößt

### 3.c auf TISCHEN und ABLAGEN

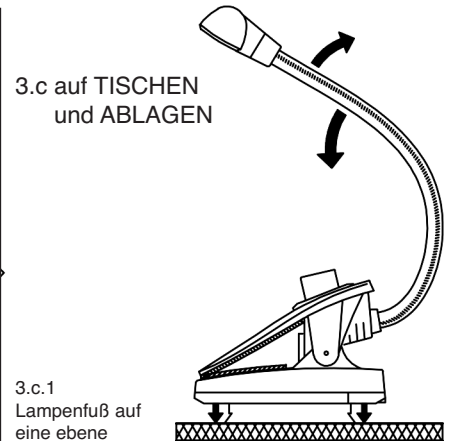

- 3.c.1 Lampenfuß auf eine ebene Unterlage stellen. Vier Auflagepunkte sorgen für einen wackelfreien Stand
- 3.c.2 Für die optimale Balance ggf. den Schwanenhals mitsamt Leuchtkopf etwas korrigieren

## 4. Licht: Schalten und Regeln

Der Drehknopf auf der Klammer des Standfußes dient als:  
-EIN-/AUS-Schalter und -Helligkeisregler (Dimmer)

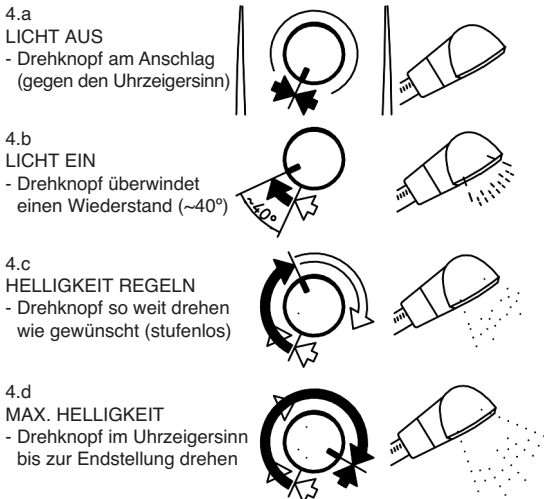

## 5. Leuchtenkopf einstellen

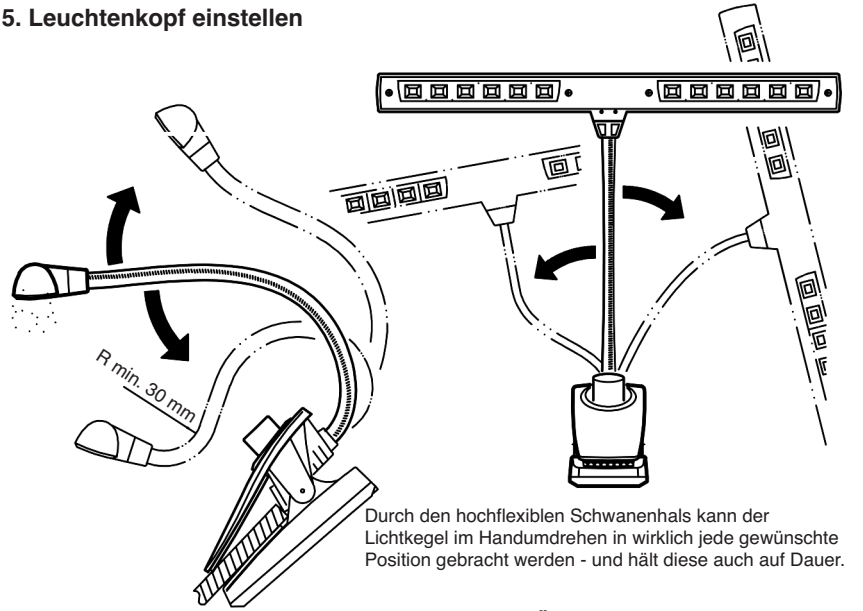

# 12295 Music stand light

## 1. Equipment & Dimensions

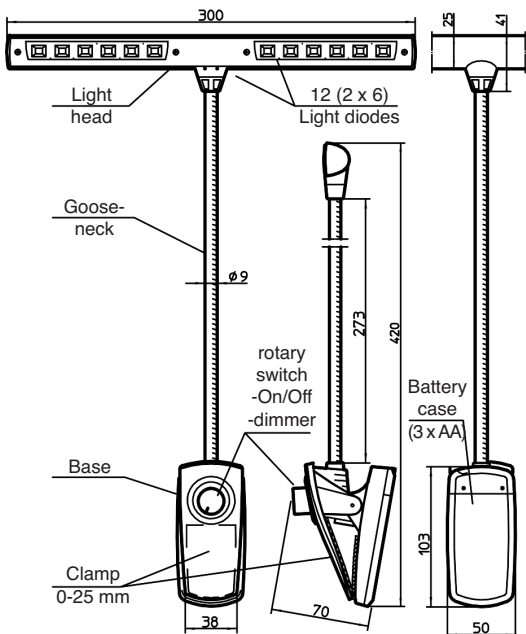

## 2. Batteries/rechargeable batteries insert or change

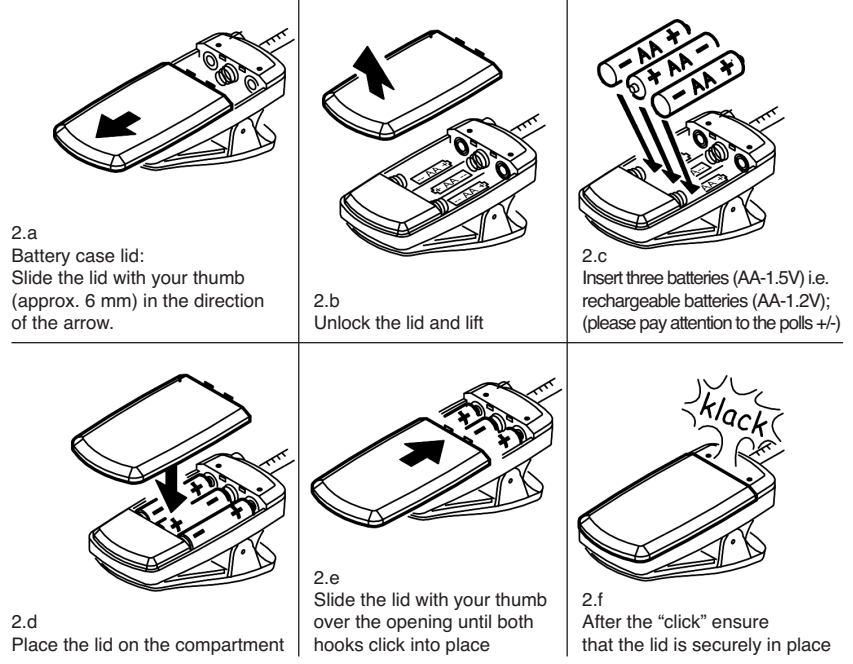

## 3. Placement of the lamp

### 3.a to the PLATES

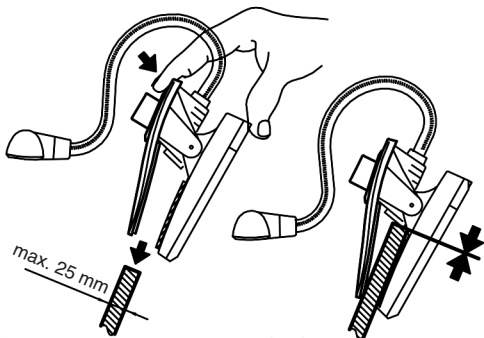

- 3.a.1 Press the clamp and slide the music desk or other plate (max. 25 mm)...
- 3.a.2 ...until the plate reaches the inside of the lower end of the clamp

### 3.b to K&M-NOTE HEADS

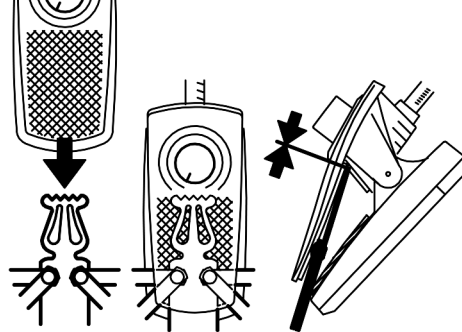

- 3.b.1 Press the clamp and slide the Lyra placed in the middle of the note head...
- 3.b.2 ...until the plate reaches the inside of the upper end of the clamp

### 3.c on TABLES and TRAYS

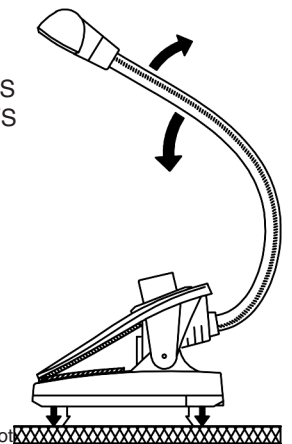

- 3.c.1 Place the lamp foot /base on a level surface. Four points of support ensure stability
- 3.c.2 To attain optimal balance adjust the gooseneck and the light head a bit

## 4. Light: Switching and control

The rotary switch on the base serves as:  
-ON/OFF switch and -light controller (dimmer)

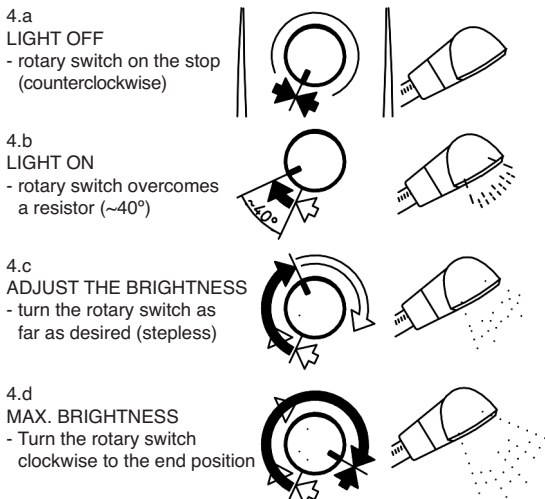

## 5. Adjust the Light Head

